

arq | linking practice and research | volume 6 · number 1 · 2002

Niall McLaughlin's Turner Centre
Wren's remarkable roofs
Gehry's requests for proposals

arq
architectural research quarterly

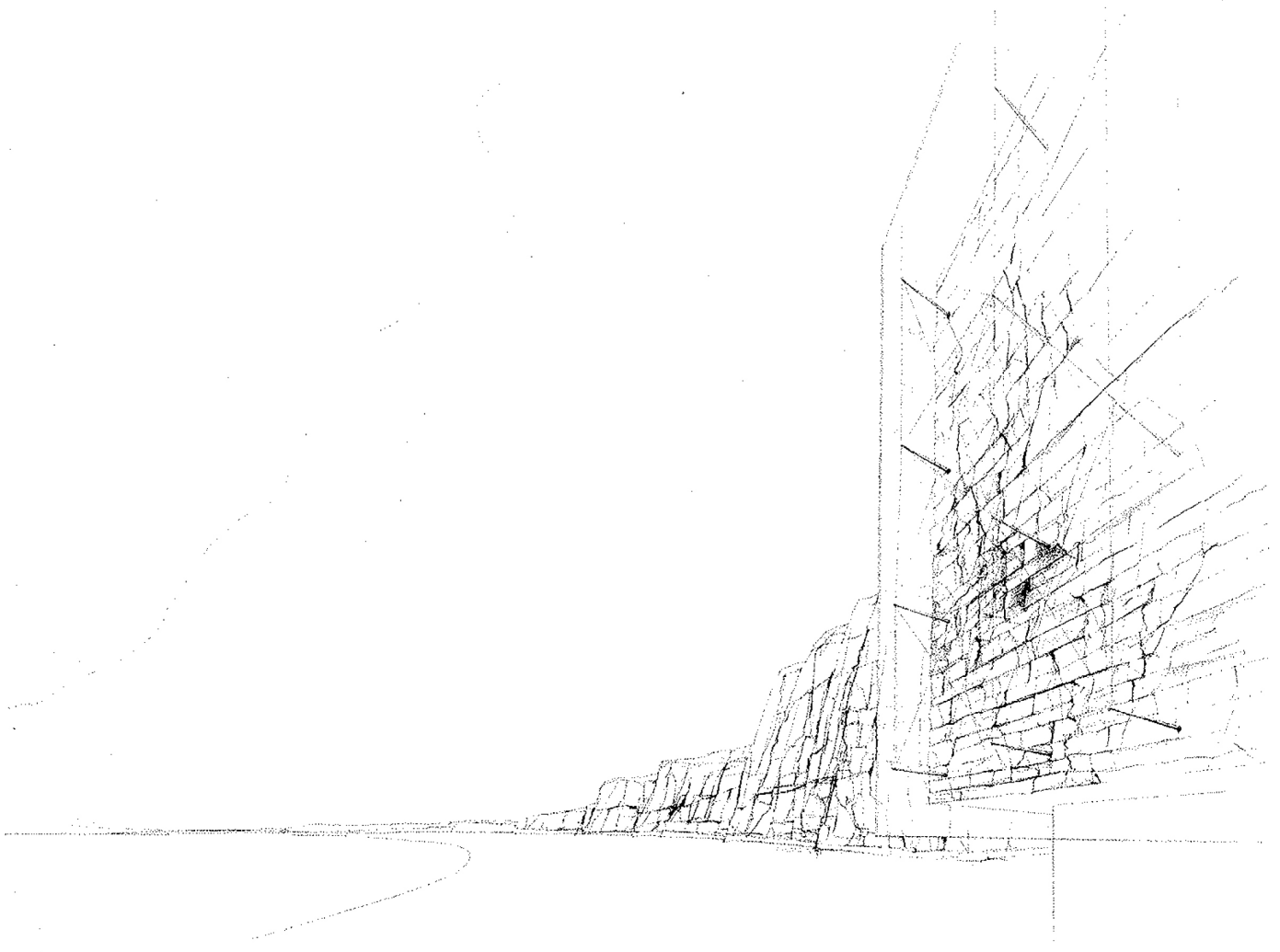

CAMBRIDGE
UNIVERSITY PRESS

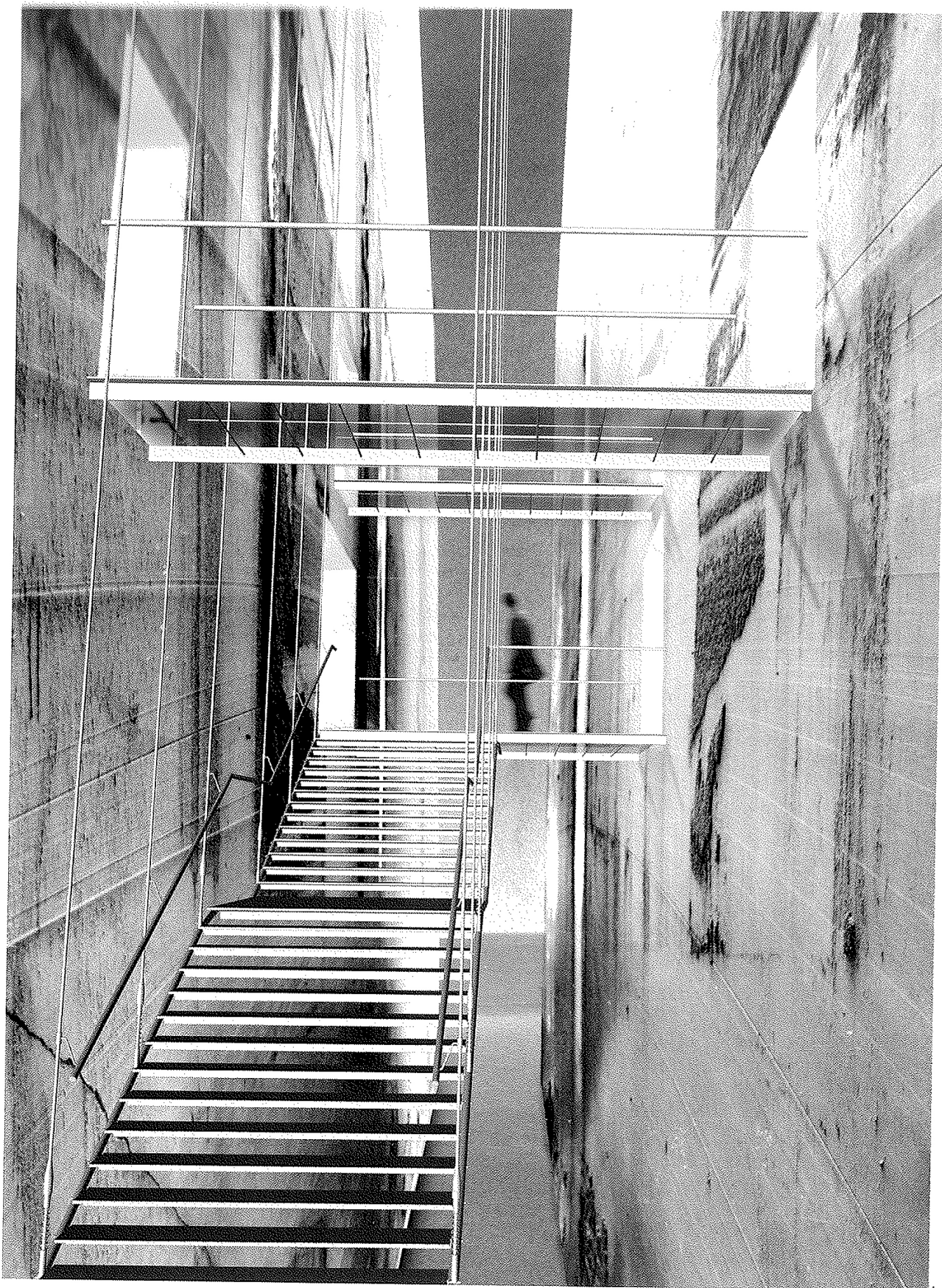

The innovative use of materials, an inventive approach to gallery lighting and clarity of organisation distinguish this short-listed competition entry for a visual arts facility on a dramatic coastal site.

Turner Centre, Margate: competition entry

Niall McLaughlin Architects

The design philosophy upon which our work is based may be summarized in our attitude towards the origins of a building, light as a primary agent of change, a respect for the nature of construction, the changing states of a building and the memory of other buildings and places.

Origins

We want to make a building where you can experience a tangible connection to the nature of its site. The first step of the design process is a teasing out of themes that are at the heart of our experience of a place. We do this through photographs, drawings, installations and stories. It is important that we find ways of moving these observations into architecture. The history of the site, its geology and environment are examined. Ideas are drawn from personal and collective memory. This is a process that should work at the level of the architect, the client and the public.

The Shack [2a] was built on an abandoned Second World War reconnaissance airbase. Remnants of its past had all but disappeared. Our design began with the history of the base and examined aircraft design, Anselm Kiefer's paintings and reconnaissance photography. When it was opened up to the public on Heritage Open Day, local people came and, prompted by the building, began to talk about their memories of the war.

Light

Light structures space. It is a primary agent of change in architecture. We design buildings as receptacles for light. The building does not receive light in a passive way, but charges it in order to make it manifest. Buildings can modulate light by combing it, diffusing it, storing it, reflecting it or changing its speed.

The sacristy in the Carmelite Monastery [2b] is a room for priests to vest themselves before going out to the altar. It is a quiet space that acts as a threshold between the everyday world of the monastery and the sacred space of the altar. Vestments are laid out for use each morning. Different coloured vestments

are used on different days of the church calendar: purple, gold, turquoise or green. The colours of the room are absolutely plain. We designed the layered ceiling to wrap around daylight, slowing it and creating a static quality in the space. A single slot of light comes directly from the sky. It falls onto the vestment counter, illuminating the fabulous garments. Light reflected off the vestments has collected their hue. In this way the rooms vests itself each day.

Construction

This practice works directly with builders, craftsmen and artists. Our intuition is that they are closer to the nature of materials than architects, who work at one remove. We try to find forms in the architecture that, by respecting the nature of construction, will express something about the materials.

In the window at Wandsworth [2c] we worked closely with a joiner, researching the history of windows and discussing the kinds of wood that are most suitable for fine machining, fixing and weathering. Perhaps, as a result, it is less overtly expressive than some of our other work.

Unfinished

An architect lecturing in London recently said, 'This building is not finished yet, at least it hasn't been photographed'. We are interested in buildings that cannot be finished. Their materials have a history. They weather, decay and are changed by demolition and extension. They are profoundly altered by occupation. No photograph or drawing can record their changing states.

The bandstand, built beside Mendelsohn's De La Warr Pavilion [2d], was designed for a terrace where locals have tea dances in the summer. We conceived the building as a kind of dancer. It can move about the terrace to set up different acoustic conditions and arrange the crowd around itself in various ways. It can hunker down against the south-west gales. When it was opened, we were surprised and delighted at the extent to which the architecture was transformed by the simple addition of a brass band.

facing page
1 The route to the art. Narrow slots – or crevasses – between the chalk-walled galleries provide a view from the foyer towards the open sea and the light and accommodate the gallery stairs

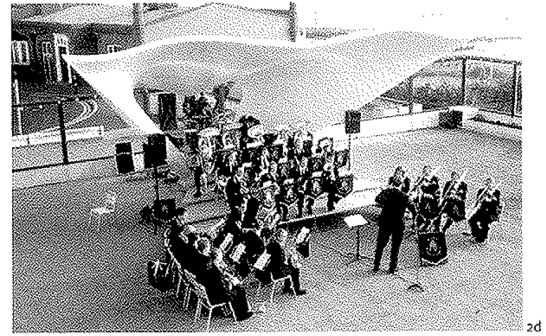
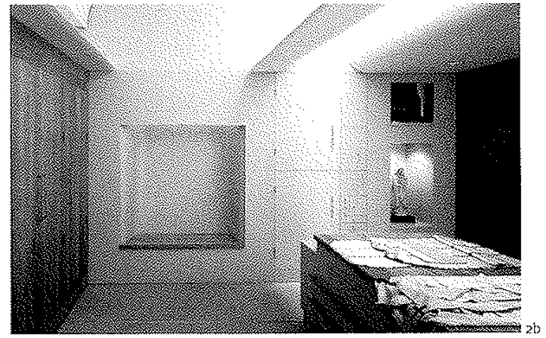

2 A design philosophy encapsulated by built works – in origins, light, construction, the unfinished and memory

a The shack – a photographer's hide-away – evokes the origins of the site, a former Second World War airbase

b The sacristy in a Carmelite monastery

has a ceiling which wraps around daylight creating a static quality in the space

c The window at Wandsworth respects the nature of its construction and is expressive of the timber out of which it is made

d The bandstand for Mendelsohn's De La

Warr Pavilion can be moved and used in a variety of ways, foreseen and unforeseen

e The house at Jacob's Ladder recalls the Tugendhat House in the way that it provides and removes a view through a sequence of spaces

Memory

Imagination is memory, said James Joyce. He suggests how new works are an assimilation of older models. In our practice, every project has one or two foster parents – buildings that are reworked through the new project. Our relationship with the older building is not always respectful, but something of its essence must survive in the new building.

The house at Jacob's Ladder [2e] is based on a memory of visiting the Tugendhat House (Mies Van der Rohe) built on a hill overlooking Brno. The sequence of circulation offers framed views over the city at significant points as you are led through the building. This culminates in a wide panorama of the city from the living room. In our design, we play with views of Oxford from a wooded hill. The view is given and taken away through a sequence of spaces. At the

end of the sequence, the swimming pool projects out into a gap in the trees. You can literally dive in and swim into the view.

The Turner Centre

Our design for the Turner Centre [3a] begins with a Turner painting of Margate [3b] in which geology and meteorology are almost fused on a single surface. This bringing together of earth and sky has a powerful resonance for us. It led us to two themes; the building has its origins in the chalk and flint of the eroding cliffs and the galleries are capable of responding to and registering changing maritime light.

We chose to design interweaving paths and spaces, integrating the building into the edge of the town. The building expressed its different uses in clearly separate, juxtaposed elements.

Niall McLaughlin Architects

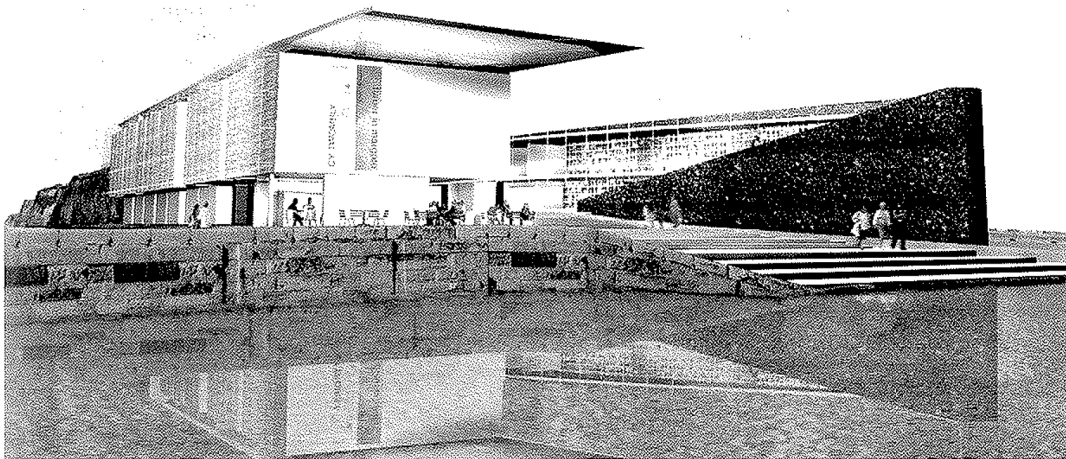

The design is inspired by Turner's painting of Margate in which geology and meteorology are fused. The building has its origins in the chalk and flint of the cliffs and the galleries have the capacity to respond and register changing light conditions

a Niall McLaughlin Architects' proposal seen from the harbour. Left to right: the cliffs, the glazed-in chalk-walled galleries, Harbour Square with the protective canopy over the outdoor café area, the foyer entrance with the education and shop area

wrapped round by the black-flint wall – the end of which forms a pulpit to the harbour
 b Margate c. 1822 by Joseph Mallord William Turner, 1775–1851. Yale Centre for British Art, Paul Mellon Collection, USA/photo: Bridgman Art Library

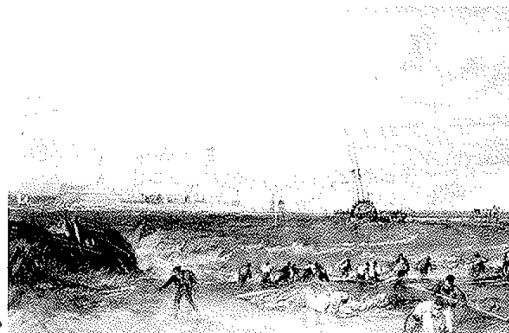

Competition background

The Turner Centre is to be located in Margate where the artist J. M. W. Turner (1775–1851) lived for many years and where he did some of his most memorable work. The seaside town is part of Thanet, where Kent County Council (KCC) and its partners are focusing on a wide-ranging regeneration programme. KCC's Centre will form a major new visual arts facility serving the south-east of England, forging connections between historical and contemporary arts and strengthening long-standing links with mainland Europe. The two-stage international architectural competition was set-up and managed for KCC by the Kent Architecture Centre. The chairman of the assessors was Paul Koralek of Ahrends, Burton and Koralek.

In March 2001, 149 named entries were received for

the first stage. From these, a short-list of six was selected for the second stage: this was judged, anonymously, in late September 2001.

Niall McLaughlin Architects' entry was described by the assessors as follows:

'A contrasting double building located close to the harbour; the building relates to the harbour Parade and presents a prominent form when viewed from the pier or across the bay. The scheme includes three highly poetic ideas: a long glass encased chalk wall facing the sea, an elegant and highly innovative gallery lighting system and a black flint wall facing the town. This wall contains the accommodation associated with the business of the gallery: offices, education, reception and shop. Pedestrian access is excellent, and good for people with disabilities. There is a clear separation between vehicular and pedestrian movement. The internal layout and circulation were considered excellent with maximum hanging space.'

Report extracts

The following is an edited version of the architects' report. The sections on the landscape, planning framework, sustainability, phasing and cost have been omitted in their entirety.

Cliffs

Turner's paintings of Margate show a blurring together of cliffs and stuccoed buildings under huge skies. This merging of cliff wall and built form is also evident along the sea walk, between Margate and

Broadstairs, where some buildings seem to imitate the scale and mass of the chalk bluffs. We are interested in this area where architecture and landscape begin to share qualities, becoming like each other.

The chalk cliffs along the sea walk have developed beautiful, almost cubist, surfaces caused by the action of sedimentation, weathering and staining [4a]. Horizontal bedding strata are crazed with minute shear fractures then stained by seeping iron oxide in solution. This gives an irregularly faceted white and orange surface. The unprotected chalk is friable and crumbly.



4a



4b

4 Turner's blurring of cliff wall and built form inspired McLaughlin's design – which exploits the opposition of delicate chalk mass and dense flint pebbles
a The chalk cliffs

have beautiful, almost cubist surfaces caused by sedimentation, weathering and staining
b As the chalk erodes, the flint is exposed as solid nodules

c The gallery spaces are walled in dense chalk ashlar, constructed like sheared bedding planes. Steel pins inserted into the joints support a protective glass shield on the sea side



4c

Soft, vulnerable chalk contains a gorgeous secret. As the chalk was deposited in sedimentary layers, creatures died in the settling mud. The hollow spaces left when the creatures dissolved were filled with silicate in solution. This hardened into lumps of tough black material known as flint. The flint is exposed as solid nodules when the chalk erodes [4b]. The black and white polar opposition of dense flint pebbles and delicate massive chalk, one born out of the other, has a special pleasure for us.

Precious substances, needing environmental stability, are sometimes stored in chalk. Think of Champagne caves. These spaces are inert, massive and cool. We propose that the gallery spaces should be made from thick chalk ashlar. They will be raised up on cross walls and the side facing the sea will be constructed like sheared bedding planes. Steel pins, resembling rock climber's pitons, will be inserted into the joints and these will hold a glass shield out towards the sea to protect the chalk [and 4c].

The geometrically simple chalk blocks of the galleries will be set against a long flint-faced wall that takes its form from the edge of the town. This wall contains the accommodation associated with the business of the gallery: offices, education, reception and shop. It inflects to orchestrate the spaces around it on Fort Hill, The Parade and the harbour edge.

The material opposition of chalk and flint are developed into an architectural organization. The flint makes a street edge and it contains the ordinary business of the building. Beyond the flint wall, the simple chalk boxes are for art and the view to the horizon. The flint is given to the town. The chalk is given to the sea.

Paths

The building becomes part of an interconnecting thread of paths [5].

The area between The Rendezvous and Fort Hill is a

coming together of different coastal walks:

- The long walk under the cliffs coming from Broadstairs.
- The walk along the pier to the lighthouse.
- The promenade along the Margate seafront passing Marine Drive and The Parade.

We have moved all of the vehicle access to the site further up Fort Hill so that the three coastal walks are connected continuously without being crossed by traffic.

A new route is being threaded through the town from Market Place up to Fort Hill. We intend to make an upper entrance to the gallery at the top of this walk. It means that visitors to the town will be drawn up Fort Road from the Market Place on a route to the gallery. This may provide an incentive for the economic regeneration of the quarter around Fort Road.

Pedestrian ramps, from the top of Fort Road, bring you down into the building at the eastern end. They connect with paths up from the car park and The Rendezvous. Each one leads into the foyer. The building becomes part of an interconnecting thread of paths.

Community

By knitting back into the old texture of streets and binding the building to the routes and paths in Margate, the design tries to make the gallery an integral part of the community. A place you might pass through on your way to somewhere else.

We have looked at the landscape and geology around Margate, the history of the town, its landmarks and the special qualities of maritime light. The architecture of the building is made from the stuff of the town. Our ambition is for the new gallery to be recognized by the townspeople, something extraordinary but known.

Part of our philosophy is to allow the robust everyday quality of the waterfront, with its seaside

- | | |
|---|---------------------|
| 5 The building forms part of a network of paths | 5 Harbour Square |
| 1 Coastal path | 6 Art route |
| 2 Neptune Outlook | 7 The Parade |
| 3 The Rendezvous | 8 Imperial Hotel |
| 4 Foyer | 9 High Street route |
| | 10 Beach |
| | 11 To station |

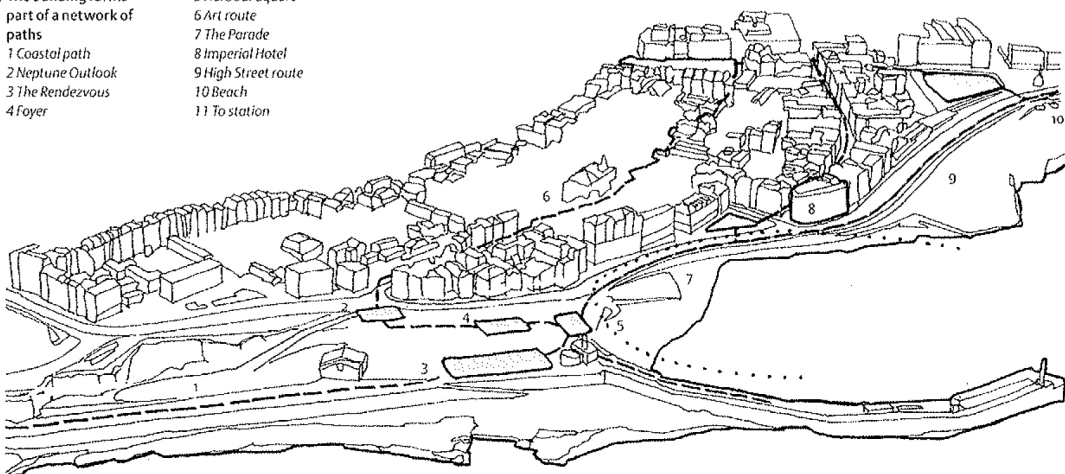

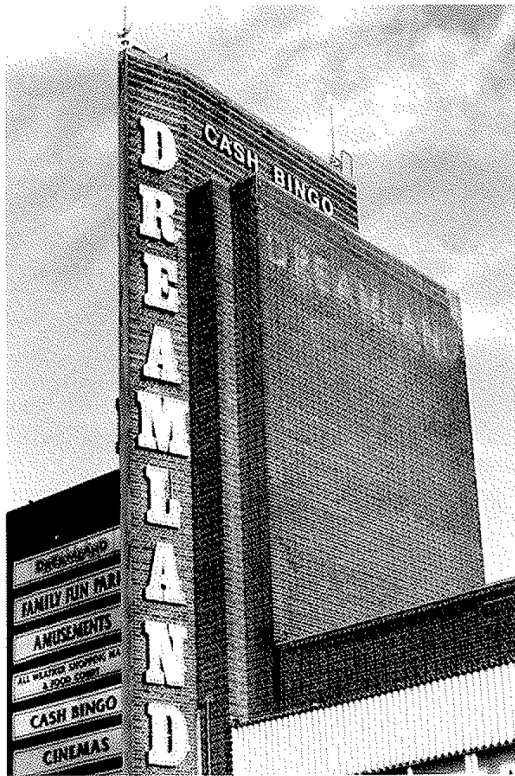

6a

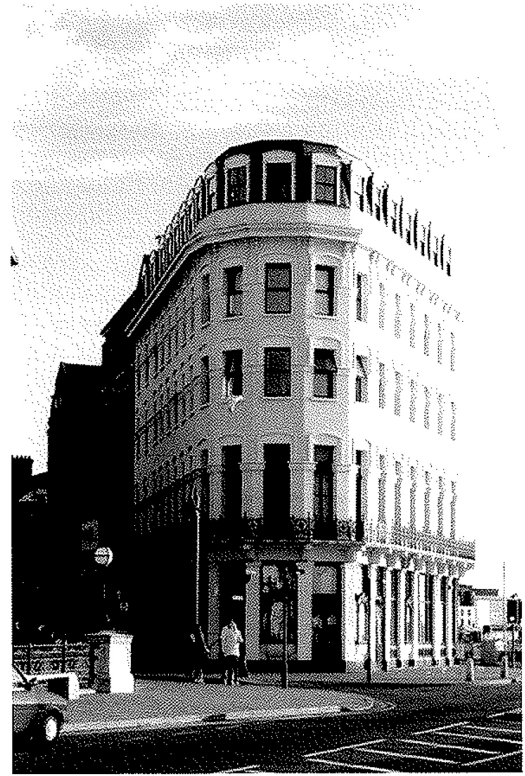

6c

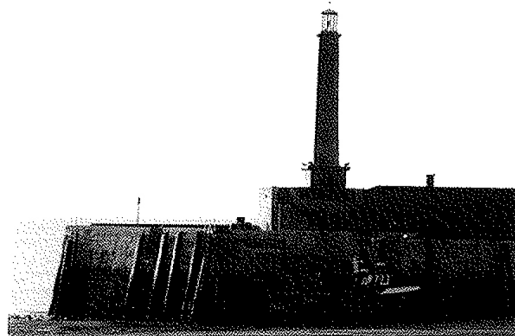

6b

6 Margate's collection of interesting thin buildings influenced the form of the flint wall at its harbour end
 a The thin brick fin of Dreamland dominates The Parade

b The pier end lighthouse overlooks the harbour
 c The corner of the Imperial Hotel (see 8 in 5) faces – and directly inspired – the black flint pulpit seen on the right in 3a

7 Access to the Centre's reception and galleries is from four squares
 1 The Parade
 2 Harbour Square
 3 Reception
 4 Galleries
 5 The Rendezvous
 6 Neptune Outlook

activities, to remain in the new proposal. The landscape strategy provides areas for people to potter about near the water. We hope that this treatment of external space will make the building feel like an intimate part of the town.

Skinny objects

The form of the wall deliberately echoes the 'Grid Iron' block further along the waterfront.

Margate has a collection of interesting thin buildings. We have made a list of obelisks and blades. The thin brick fin of Dreamland [6a] dominates the promenade, the lighthouse [6b] on John Rennie's Stone Pier, the slim cupola on Droit House and the old Imperial Hotel [6c] at the junction of High Street and Marine Drive which is like a modest echo of the Grid Iron Building in New York.

We would like to add to this collection by turning the flint wall back on itself to form a thin 'pulpit' overlooking the harbour [see 3a]. The form of the wall deliberately echoes the Grid Iron Building further along the waterfront. It recreates what used to be Paradise Street and begins to make a new space on the harbour front.

The nose of the chalk wall and the cupola over Droit House are similar in scale and, seen from the promenade, these two pillars will frame the square overlooking the arc of the harbour.

Squares

Four squares are formed [7]:

- Harbour Square. We have made a new enclosure beside the harbour. The steps up to the entrance level of the gallery are continued across the square

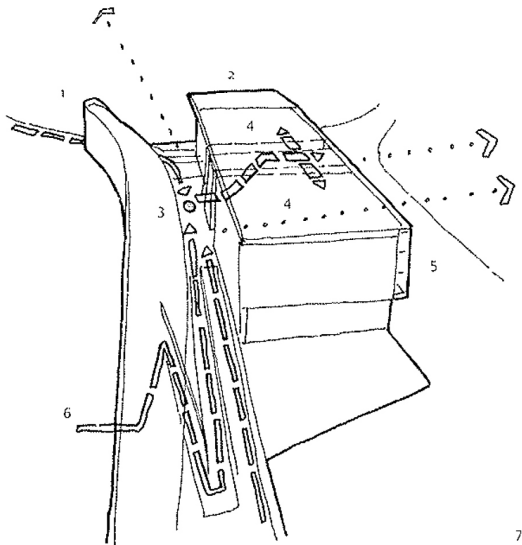

to link up with the boat slip, suggesting an orchestrated descent into the water. The pavement on the promenade ramps gently up to the building's west entrance. The roof of the chalk box projects out over this space to make a covered terrace. The café can be accessed directly from this new space. The retail outlet for the gallery is set against the flint wall as it extends out. We imagine that the books and posters displayed along this wall will form a backdrop to the square.

- The Rendezvous. The north side of the gallery has a scale that reflects its seaward aspect. The chalk and glass facade dominates the space between the building and the sea. The lifeboat station and Droit House frame the waterfront beneath. We imagine this square being used for day to day waterfront activities such as preparation of dinghies, kitting up for diving or assembly of fishing gear. Long benches cross the square.
- Neptune Outlook. We have made a new protected terrace with an outlook on Fort Hill. It is linked by ramps to the gallery building. The flint wall and the natural cliff edge frame this upper terrace. Walkers coming along the new art route from the town centre will enter the gallery from this little square. It is also the drop-off point for buses before the vehicle ramp descends into the car park.
- The Parade. There is a small, shallow square looking out into the harbour on the seafront beyond the Turner Centre. The corner of the flint wall reinforces the enclosure of this existing space by echoing the Grid Iron Building at the other end. The pairing of the Grid Iron Building with the prow of the flint wall can be compared to pinball flippers.

The gorge and the crevasse

The broad expanse of the harbour is discovered through the high, widening space of the foyer [8a-g].

All along the cliffs on the walk to Broadstairs there are narrow slots cut into the chalk to allow access down to sea level. These sheer crevasses provide a strongly contained view of the horizon. The compression of the route down underlines the great expanse of the ocean.

The foyer area of our building is like a narrow gorge. If you enter from Neptune Outlook, it opens out, spilling into the space of the harbour. At its narrow end, pathways feed into the building. These bunched ramps bring visitors down from Fort Hill, up from the car park and across from the waterfront, depositing them in front of the reception desk. The broad expanse of the harbour is discovered through the high, widening space of the foyer.

The sheer walls of the foyer are made from polished chalk ashlar on one side and vertical stainless-steel panels on the other. The chalk boxes have narrow slots between them that look directly out to the sea to the north [1]. These slots set up the route to the art. It is a movement towards the open sea, towards light.

The weather and the work

The walk through the three galleries is conceived as a ferrying between static enclosed spaces containing art, and viewing spaces which frame changing views of the sky and the sea.

The galleries are all arranged on one level and a circular route links them. You will naturally visit every gallery on this route going clockwise or anti-clockwise. The walk through the three galleries is conceived as a ferrying between static enclosed spaces containing art, and viewing spaces which frame changing views of the sky and the sea.

The orientation space adjacent to Gallery 3 has an open screen made of chalk blocks separated by pins, like stone stored in a quarry. Sea light comes through the cracks between the large lumps of matter. Each time you move from one gallery to another you cross the line of a crevasse and glimpse the horizon.

Openings in the walls of Gallery 1 allow the visitor to step out into the space between the rough chalk wall and the glass facade [9]. The matrix of steel pins extends away on all sides. Having stepped outside the line of the building, the whole wide space of sky and sea is given.

Clouds

We imagine our galleries as abstract empty landscapes, the floor and walls as permanent ground, the ceiling, like the sky, capable of endless change.

We would like to design a gallery space that has a strong independent architectural presence and is also a container which supports, rather than competes with, an endless range of artistic works (some impossible to imagine yet). This is an important matter of architectural tact.

In order for each exhibition to have the greatest possible scope, it would be good to have a large

- 8 Turner Centre design proposal
- a Site plan
- 1 Droit House
- 2 Turner Centre
- 3 Lifeboat station
- 4 Car park
- 5 Fort Hill
- b Cross section through Gallery 1
- 1 Gallery 1
- 2 Art store and loading bay
- 3 Administration
- c Cross section through foyer and

- orientation space
- 1 Resident artist and members' room
- 2 Orientation space
- 3 Gallery 3
- 4 Lobby and auditorium
- 5 Foyer
- 6 Education
- 7 Shop
- d Long section through foyer
- e North elevation
- f Gallery (upper) level plan
- 1 Orientation space

- 2 Gallery 1
- 3 Gallery 2
- 4 Gallery 3
- 5 Education
- 6 Administration
- g Foyer (lower) level plan
- 1 Droit House
- 2 The Rendezvous
- 3 Harbour Square
- 4 Café terrace
- 5 Café
- 6 Auditorium
- 7 Art store, workshops and loading bay
- 8 Foyer
- 9 Shop

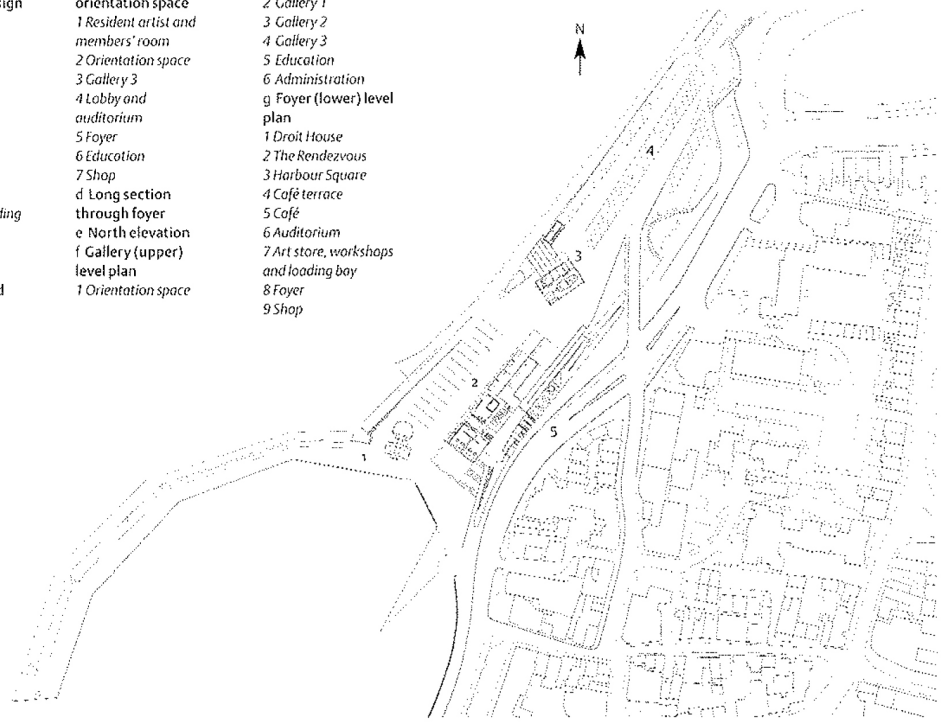

8a

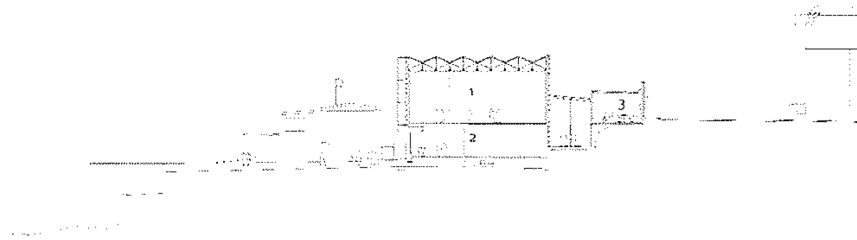

8b

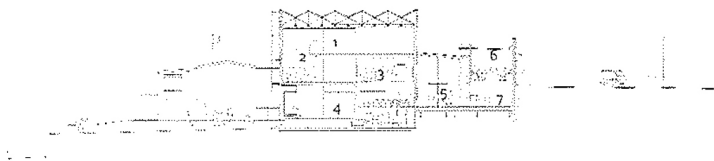

8c

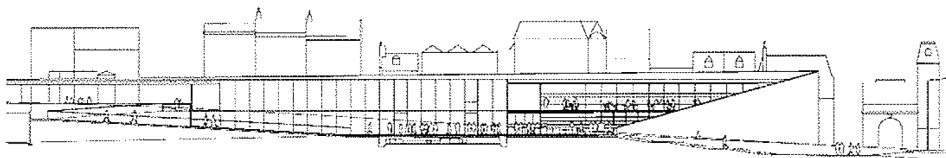

8d

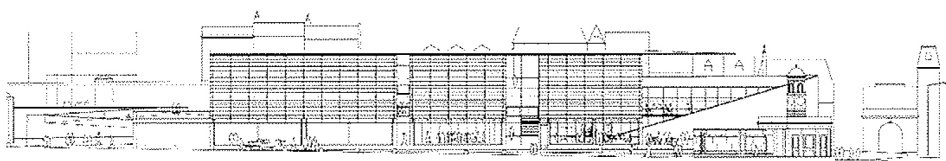

8e

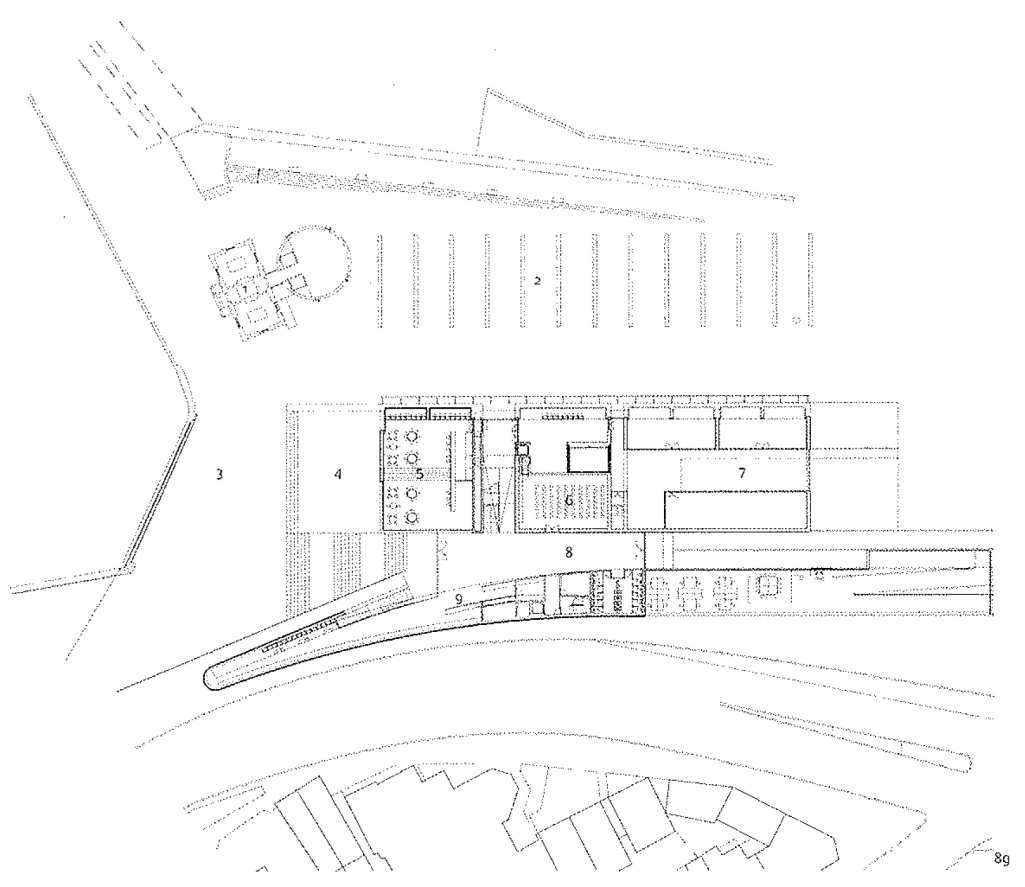
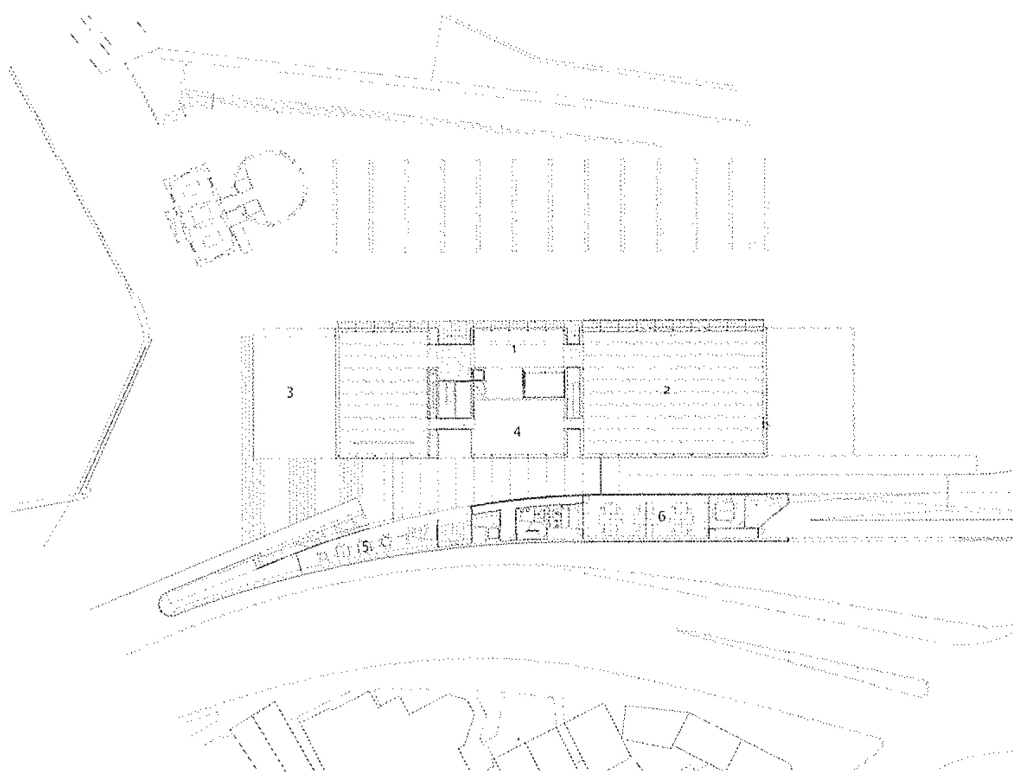

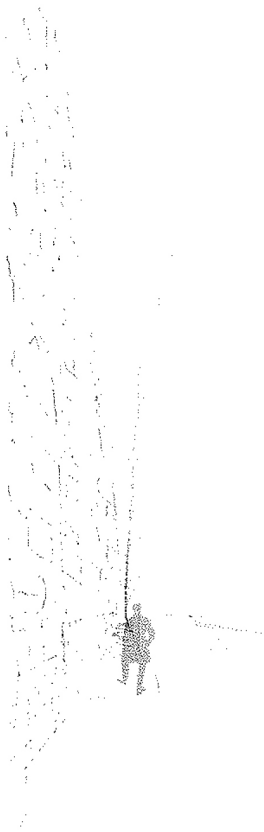

9

empty room that is capable of infinite transformation. It would not be a tabula rasa, but a space of definite character. We imagine our galleries as abstract empty landscapes, the floor and walls as permanent ground, the ceiling, like the sky, capable of endless change [10a and b].

To follow the metaphor of landscape, we suggest an apparatus for environmental change that is like a cloud. In other words, it is a phenomenon that completely alters the atmosphere then moves on. We think that, in its substance, it would have the ephemeral material and luminous qualities of a passing thing. It would float in the upper reaches of the gallery without touching the edges.

The cloud will be a horizontal layer occupying the zone of the structure. Deep trusses are used to give large, clear gallery spaces [10c and d]. The tops of the trusses will be clad in alternating north-facing glazed and south-facing opaque insulated panels, so that light is collected from the sky vault with little direct sunlight. Within the depth of the truss a flexible arrangement of specular faced blackout blinds will reflect any direct sunlight back to the outside. This will allow a variety of light levels, from blackout to the highest parameters of the design criteria. It is most important that, while harmful light is taken out, the changing moods of the sky can be experienced in the ceilings of the galleries.

The lower edge of the structural truss will be clad in woven stainless-steel fabric, looping between

9 Openings in the wall of Gallery 1 lead to a walkway between the chalk wall and the glass facade. In this vertiginous space, a view of the whole wide space of sky and sea is given

10 The galleries are imagined as abstract empty landscapes. The floor and walls form the permanent ground but the ceiling, like the sky, is capable of endless change. The objective was for a container that supports rather than competes with the exhibits
a A horizontal layer of woven stainless-steel fabric suspended between lines of support forms the gallery 'ceiling'. Its

appearance can be modulated by light – natural and/or artificial – from below and/or above. In certain conditions it appears light and transparent (see c) ...
b ... while in others it can appear heavy and opaque, like a storm cloud (see d). Note the slot in the wall beyond: this provides a glimpse of the sea and leads to the walkway seen in 9

c and d Section through the cloud roof in two modes
1 Double-glazed fixed light
2 Insulated metal roof panel
3 Gutter
4 White soffit
5 Specular upper surface of blind
6 White surface of blackout blind

7 Spring blind tension coil
8 Blind bar moves along line of truss
9 Blind drive motor
10 Upward facing washlight
11 Light track in 'up' position
12 Woven stainless steel held by cramps
13 Track mounted feature light

5' Specular surface reflects light and heat
6' Blackout achieved by covering rooflight
7' Tension maintained by spring coil
8' Blind bar has moved to top of truss post
9' Blind motor
10' Inner washlight is switched off
11' Outer washlight deployed to illuminate ceiling 'cloud'
12' Woven stainless steel reflects and becomes opaque

fixing clamps. The variable transparency of this layer is the key to change in the space. The woven stainless-steel fabric is transparent when the space behind it is brighter, but it becomes opaque if it is lit from the front. We propose to mount light fittings above and below the pleats of the cloud fabric. It will be possible to modulate the transparency of the surface by mixing daylight, artificial light from above and artificial light from below. This should give an endless range of light levels and transparency. On the best days, when sunshine, showers and clouds are working together, we imagine the under-surface of the ceiling to be a screen for shadow and light.

Everything which is needed to support exhibitions will be held within the cloud. This might include light control blinds, motors, sound equipment, public address system, video projectors, deployable screens, smoke detectors, fibre-optics, electrical cabling and tracks. In some conditions these will become visible behind the first diaphanous layer.

Gallery 3, containing the drawings, will have another floor above it. So it is not directly below the cloud and it has no daylight. Gallery 1 and Gallery 2 are directly beneath the cloud and this allows the most flexible use of these spaces. The floor above Gallery 3 is used for the artist in residence and the members' room. They will have the special pleasure of being aloft, skimming the under-surface of the luminous veil.

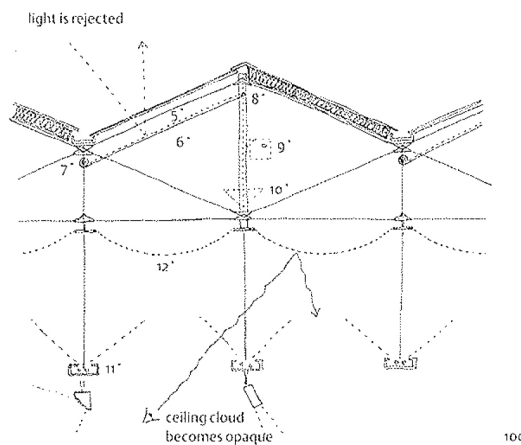
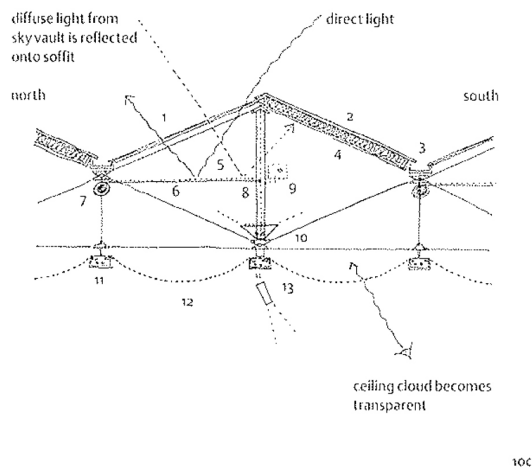
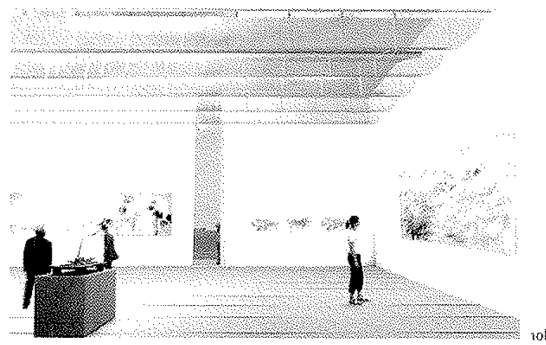
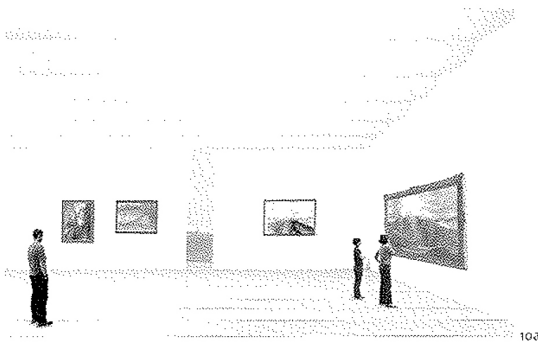

The flint wall

The facing of the flint wall will be polygonally shaped select-knapped flint in blue-grey shades [11a]. The dark wall will be used to heat a cavity behind [11b] and the warmed air will be used as part of the environmental strategy for the gallery. Openings in the flint wall will be designed as sharp arrises. The composition of the arrises against the single surface of the flint wall will emphasize the enclosure along Fort Hill. The sweep of the concave crescent wall descending the hill will make a dramatic approach to the harbour.

At the brow of the hill the wall is single storey, allowing a modest entrance to the gallery. The top remains level along the street so that the wall is tallest at the opening into the harbour. An outdoor stair takes visitors from the entrance up to the top of the flint wall at its apex. This viewing point looks out over the bay. It links to the terrace associated with the education room. This is a place for kids to stand at the prow of the building and lean out over Margate Harbour. It might be named Top Spot.

The chalk boxes

Sections of chalk ashlar can be cut to lengths of 3m and laid in a stretcher bond pattern to form the wall [12a-c]. The outer (north) side of the facade will have an irregular facing made from the pattern of shear fracture when the chalk blocks are broken rather than cut. Each cut chalk block will be snapped along

a scored line to create an irregular edge. This will be used as facing.

At regular vertical centres, steel needles will be driven into the bedding lines of the chalk and fixed to steel within the substrate [see Cover, 4c and 9]. These needles will support large sheets of 20% opalescent fritted glass. There will be a space of 1m between the chalk wall and the glass. It will be possible to step out of Gallery 1 and stand within this space. The view of the sea from within the construction is intended to be at least a little vertigo-inducing.

While researching chalk ashlar we discovered and visited Marshcourt by Edwin Lutyens (1927) which uses panels of knapped flint within chalk ashlar walls.

The building on the site

This design uses the cliff edge as a setting out point for the parts of the building. Our intention is to build off the existing edge in order to avoid excavation and to mark the line of the old coast. The land-side edge of the foyer space is the old cliff and the rooms within the flint wall step up with the slope of the land. The ramps, which descend from Neptune Outlook, are following the line of the geology.

By reinforcing the old section of the cliff we naturally make some spaces which are very far beneath the finished surface of the earth on Fort Hill. These elements will be environmentally very stable and they will be used as part of our heating/cooling strategy.

Environment

Gallery spaces present a number of diverse problems in creating the appropriate environments. The requirements to protect and conserve art often conflict with the need to display it to the public, and the conditions required doing this. The competition brief has sensibly addressed this by calling for a series of spaces tailored for specific purposes. These range from the large gallery for robust art with variable climate suitable for mass occupancy, to small conservation galleries for unique works with highly controlled climates.

The environmental strategy developed for the building draws together all these diverse requirements with a solution that maximizes the energy efficiency of the overall construction and harnesses natural energy sources wherever possible.

Passive control

Buildings are generally designed for the comfort of occupants to control temperature between the extremes of 20 and 30°C. The conservation of the collection will generally require control of the humidity between 45 and 65%RH. This defines a design environmental range.

Natural air conditioning

The moderate and stable climate of the United Kingdom is a result of our geographical situation, lying at the confluence of the warm equatorial air streams, the cold polar air streams, the wet maritime air streams and the dry continental air streams. In the same way our building sits between the cool moist air from the sea to the north and the warm dry air from the land to the south, and uses this fact to achieve stability. The environmental conditioning strategy draws from these two sources of natural conditioning and mixes the airflows to achieve an optimized condition for fresh air supply to the building.

Warm air from the south and cool, damp air from the north are drawn into the building through the podium undercroft and a system of builders work ducts, to a plant room at the heart of the building, beneath the foyer [13a and b]. In the plant room the air streams are mixed to achieve an optimum condition matching the building's demand for heating or cooling. Further heating or cooling is then applied in separate air handling units serving each of the galleries to provide comfort conditioning or close control as required. Air is distributed through builders work voids and plenums in the structure.

Low energy ventilation

The ventilation systems for the spaces use low energy, natural displacement ventilation to create the air movement and ensure circulation of fresh air within the galleries and ancillary spaces. Displacement ventilation uses the heat from people and solar gain to move air by natural convection, the air being introduced at floor level. The associated mechanical ventilation systems can therefore be extremely low energy, as it is not necessary to force room air movement.

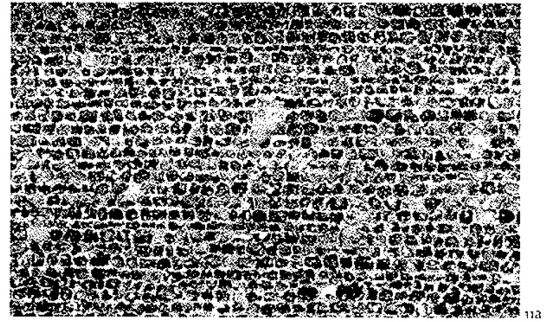

113

The system has a number of advantages. As the air moves by convection from floor to ceiling, the layout of the space does not affect the efficiency of the ventilation, allowing partitions to be erected for picture hanging, or large installations. Having a low energy mechanical ventilation system, rather than natural ventilation, allows us to use natural heating/cooling effects, provide filtration to remove salt and to achieve heat recovery, thus providing a system that is much more efficient overall than natural ventilation alone.

Passive cooling

The level of the gallery spaces is to be raised slightly above the existing ground level, to avoid the risk of flooding when the seafront is inundated with waves. This creates a shallow undercroft space, in which will be constructed a thermal labyrinth. This labyrinth, being sheltered by the building, will be at a temperature close to the mean ground temperature, like a cellar or cave. Circulating fresh air through this labyrinth provides heat exchange with the ground to cool the air before it enters the ventilation system. The cooling effect of the labyrinth will be further enhanced by circulating cool night-time air to pre-cool the structure and increase its capacity to take heat from the day-time supply air.

The use of the undercroft as a pre-conditioning system also has advantages in removing contaminants from the air. The large, cool surface area that the air comes into contact with, encourages the deposition of aerosol droplets, that would otherwise bring salt into the building. This initial cleaning of the air removes much of the burden on the filters in the ventilation system, improving their efficiency and economy.

The building will comprise a number of heavyweight elements of construction, which in themselves will contribute directly to the climate control of the gallery spaces. As heat is introduced into the galleries, either from people, artificial lighting or the sun, the temperature of the surrounding structure will rise much more slowly than the air in the space would on its own. This mitigates the heat build-up and lowers the apparent temperature sensed by the occupants. Once again, circulating cool night air will enhance this effect by pre-cooling the structure before the start of occupancy each day.

11 The sweep of the concave crescent-shaped flint wall emphasizes the enclosure along Fort Hill. Internally, it accommodates a number of subsidiary functions including administration, bookshop and cloak. A typical polygonal knapped-flint wall surface. Flints are dark blue/grey and bedded in mortar. This is a traditional finish in flint areas
 12 Flint wall section

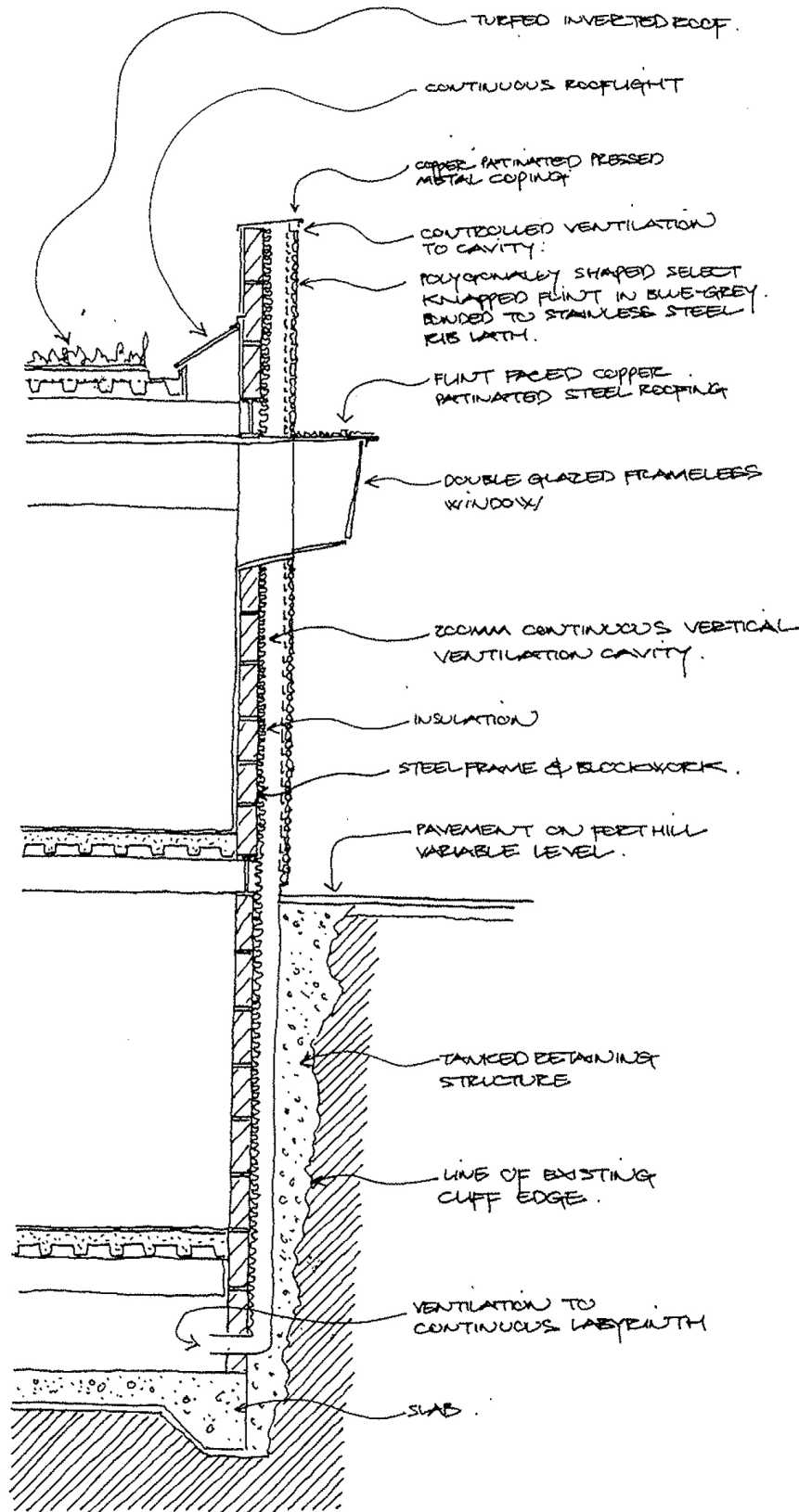

FLINT WALL SECTION .

11b

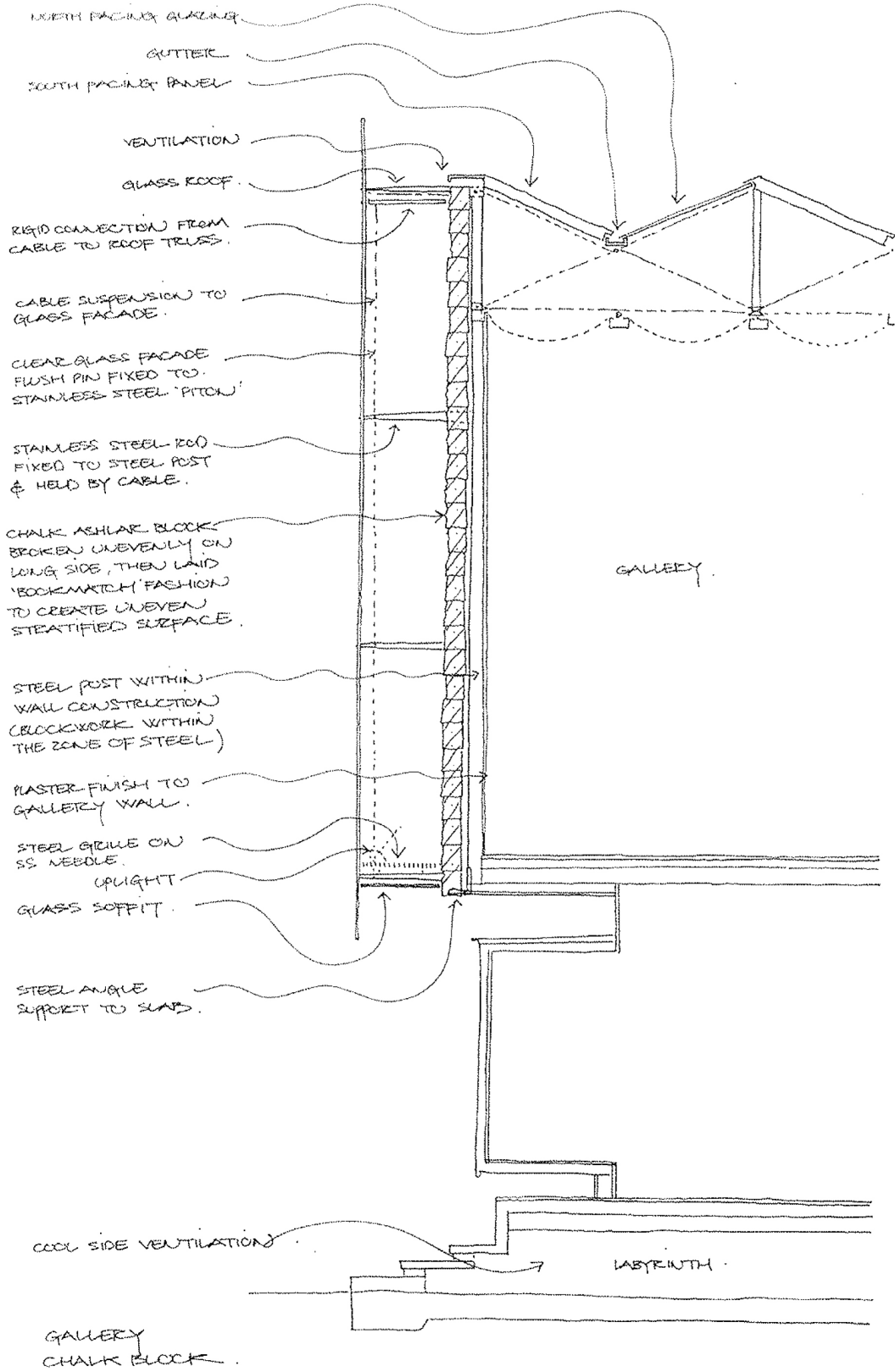



12b

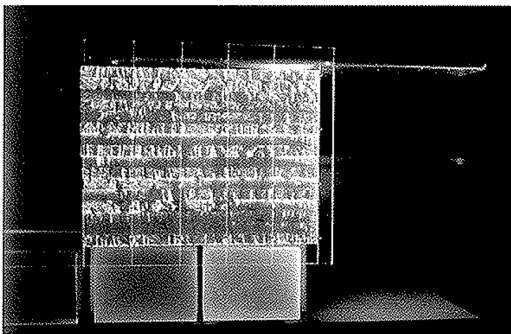

12c

a The gallery walls are formed in chalk ashlar units 3m long laid in stretcherbond. The

outer face will have an irregular facing formed by the shear fracture when the blocks are broken

b Chalk wall section
c Chalk cliffs. Note the horizontal strata
d Exploratory model of chalk facade behind glazed screen

Passive solar heating

In the winter the heating effect of drawing air from the south side of the building is enhanced by the use of the flint wall to capture heat from the sun directly. Air for the ventilation system is drawn from the cavity within the flint wall, where it has been warmed by the solar energy absorbed by the black face of the knapped flints. In the summer, when the heat is not required for the ventilation systems, the heat from the wall is captured by embedded pipework to pre-heat water for domestic consumption, while the cavity is left open to ventilate freely and prevent the flint wall from overheating the adjacent internal spaces.

Public areas

The foyer

The foyer is the space between the flint wall and the chalk boxes [14]. It overlooks the harbour and offers glimpses through the slots between galleries towards the open sea. All of the ways into the building deposit visitors in front of the reception desk. It operates as a single point of control with views of all entry doors. It is directly adjacent to the entry to the gallery spaces.

The bookshop, the café, the auditorium and the gallery route all open directly off the foyer. Lifts, stairs, WC area and crèche are also accessed directly from the foyer. The sloping surfaces and ramps around the building allow a minimum 1:20 disabled access to the foyer from the harbour, the car park and the Fort Hill entrance.

The quality of light in the foyer will be very different to the rest of the building. The roof light allows direct south light to cast shadows along the walls of polished chalk. Baffles above and beneath the roof light will create a play of complex shadows along the wall. This will contrast with the controlled, diffuse north light used in the gallery spaces.

The café

The café sits on the edge of the harbour with a raised terrace overlooking the activity of the two squares. The oversailing roof of the gallery shelters the terrace. The café can be entered from the foyer or the Harbour Square. This will give life to the square and it allows the café to function beyond gallery hours. We consider the café to be an important threshold zone between the galleries and the bustling world of the harbour.

The retail outlet

Situated at the western end of the foyer, visible from all entrances, the bookshop is conceived as an extension of the central foyer space. The back wall of the bookshop, intended for postcards, posters and books, faces a glazed screen overlooking the Harbour Square. Looking from the square, it acts like a large shop window, suggesting the books and images on sale. Within the bookshop it works like a long gallery with window seats opposite shelves to encourage browsing.

The auditorium

The auditorium, with its associated accommodation, is situated directly off the entrance area so that people can spill out to use the foyer after an event. The space contains flexible seating, a projection room and a visitor's room.

The education space

The education area overlooks the harbour and it has its own external terrace that looks onto the viewing point over the harbour. We want this space to occupy a stimulating position, adjacent to the art with views of the town and the harbour.

The art route

Vehicles bringing art to the gallery will access the building at the eastern end, using the new ramp